

CEIA THS/PH21[®] series

High Performance Pharmaceutical Metal Detection Systems



- ✓ Tablets
- ✓ Capsules
- ✓ Gel Caps
- ✓ Powders
- ✓ Granular
- ✓ Liquids
- ✓ Syrups

- Superior and Consistent Detection
- Enhanced Product Throughput Rate
- Preventive Maintenance Not Required
- Maximum Configurability / Integration
- FDA 21 CFR Part 11 Compliant
 - Data Security • Data Integrity • Data Traceability
- Design and Construction Compliant with GMP criteria and FDA Title 21 CFR Parts 210 and 211



State-of-the-Art Metal Detection Solution for Compliance with Directive 2003/94/EC and FDA Title 21 CFR 210-211 Requirements

CEIA THS/PH21 Metal Detection Systems offer detection, construction quality and reliability characteristics that make them the most suitable and effective solution for the automatic elimination of metal contaminants

FDA 21 Part 11 Compliant

- ✓ **The THS/PH21 Metal Detector Series is a high-sensitivity, high-precision measuring instrument.** The response from the device is used to directly command ejection of the contaminated product and to verify that it has in fact been eliminated.
- ✓ **FDA Code Title 21 Part 11 prescribes rigorous criteria for access to programming and computer data protection, which have been fully adopted in the CEIA THS/PH21 Series firmware.** User access is only possible via a User Name and Password login under the control of the System Administrator, who programs and manages individual user profiles and user functions. As a result, the requirements for security, integrity and traceability are satisfied.
- ✓ **All events performed by the THS/PH21 Metal Detector are recorded in a data log** to comply with FDA Part 11 protocol and assist in root cause analysis. The events include detection, ejection, program operations, passwords and periodic functional test phases using standard test samples.



■ Validation Solutions Available:

- ✓ Calibration Standards
- ✓ Validation Manuals
- ✓ Comprehensive Service & Support
- ✓ Compliance Tools
- ✓ On-line Production Data Validation

Continuous Embedded Self-Calibration Control

Continuous embedded self-calibration control for maximum repeatability and performance consistency over time and with environmental changes

By means of specific signals sent to the transmission and reception chain of the Metal Detector, constant monitoring of the detection characteristics is carried out, with consequent constant compensation for any variations caused by environmental factors. **The result is system stability and constancy in detection performance and product effect neutralization.**

Continuous Auto-Test Function Ensuring Maximum Production Safety

Special electronic stimuli are sent to the transmission and reception chain of the THS/PH21 Series Metal Detector, causing variations in the detection signals which provide checks on detection characteristics. These variations are compared with the reference values stored in the memory of the metal detector at the time of the factory calibration test. This produces an automatic certified check of the system's sensitivity.



QUALITY CONTROL TEST SAMPLES

CEIA OFFERS SAMPLES FOR QUALITY ASSURANCE TESTING CERTIFIED IN COMPOSITION, SIZE, AND ELECTROMAGNETIC RESPONSE

New Auto-Learn System

A new Auto-Learn System provides simultaneous maximum sensitivity to all metals starting from a single learning transit. The THS/PH21 Series employs an exclusive Auto-Learn system for pharmaceutical products, which allows optimization of the detection sensitivity to all metals with the maximum speed and precision, equivalent to hundreds of conventional learning transits. This results in levels of precision and efficiency never before obtained.

New Diagnostic Tools

The THS/PH21 Series introduces new tools for the installation and maintenance technician to measure the environmental compatibility of the metal detector. These are functions that would otherwise have required the intervention of external instrumentation, now implemented in the microcomputer control of the device itself.

The measurements include general mechanical and electromagnetic environmental compatibility.

Modern, Rugged and User Friendly Interface

■ Rugged, antivandalic stainless steel keyboard

The THS/PH21 Metal Detector Series maintains full compatibility with programming and parameter selection procedures already implemented in earlier versions of the THS/PH21. In addition, there is a new organic graphic display with extremely high contrast (3000:1) and a viewing angle up to 180°, along with an extended alphanumeric keypad for quick keystrokes.

■ Industrial rate design

■ Rapid data entry with extended keyboard

■ Easy to read, high-contrast graphic display

■ Quick access function

A new function, simply activated by pressing a dedicated key, allows the most frequently-used functions to be directly recalled. These functions are programmable by the operator, and maintain the access protection criteria according to FDA Title 21 Part 11 requirements.



Ejection System Specifications

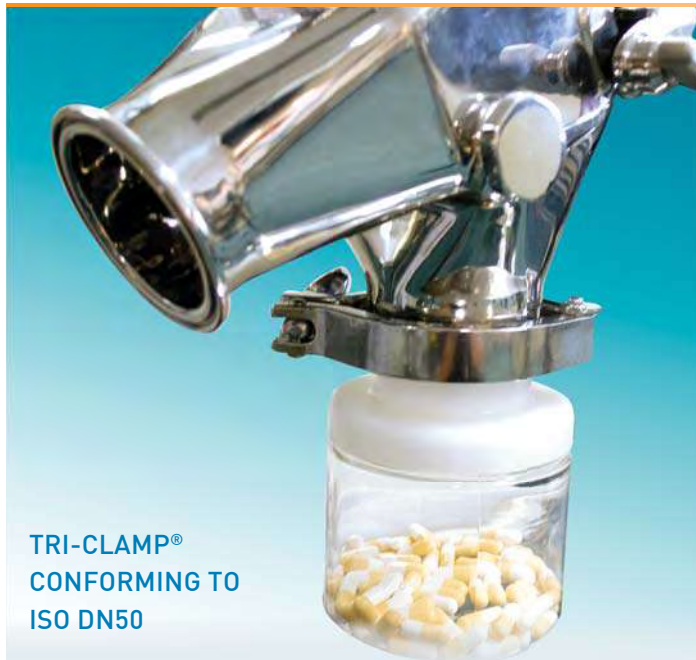

TRI-CLAMP®
CONFORMING TO
ISO DN50

EASE OF MAINTENANCE

MAINTENANCE IS FAST AND DOES NOT REQUIRE THE USE OF TOOLS TO ASSEMBLE AND DISASSEMBLE THE COMPONENTS

- Monolithic AISI 316L Stainless Steel Body
- Extremely quick response time provides full safety in the ejection of contaminated product
- Advanced mechanical and electronic solutions guarantee the integrity of the inspected product
- Double confirmation system carefully monitors and controls the complete opening and closing of the ejection flap
- Easy assembly and disassembly of the parts in contact with the product: no tools required
- Tri-Clamp® conforms to ISO DN50 and is available as an option

* Tri-Clamp® is a trademark registered by Alfa Laval Inc

Bluetooth® Connectivity

In the THS/PH21 Series, local connection to the maintenance technician's computer no longer requires physical access to the interior of the detector or the use of unwieldy connection cables. **The Bluetooth connection** can be used for programming, monitoring of the signals via the **CEIA MD-Scope program** and the transfer of the data contained in the Metal Detector's events memory.

Sophisticated Network Communication Capabilities

The THS/PH21 Metal Detector Series can be linked to an Ethernet network (optional module required, part # 57194). In association with the THS Production Plus Software it enables remote management of production, collection of all technical and operational events, generation of statistical and traceability reports in compliance with FDA 21 CFR part 11 requirements.

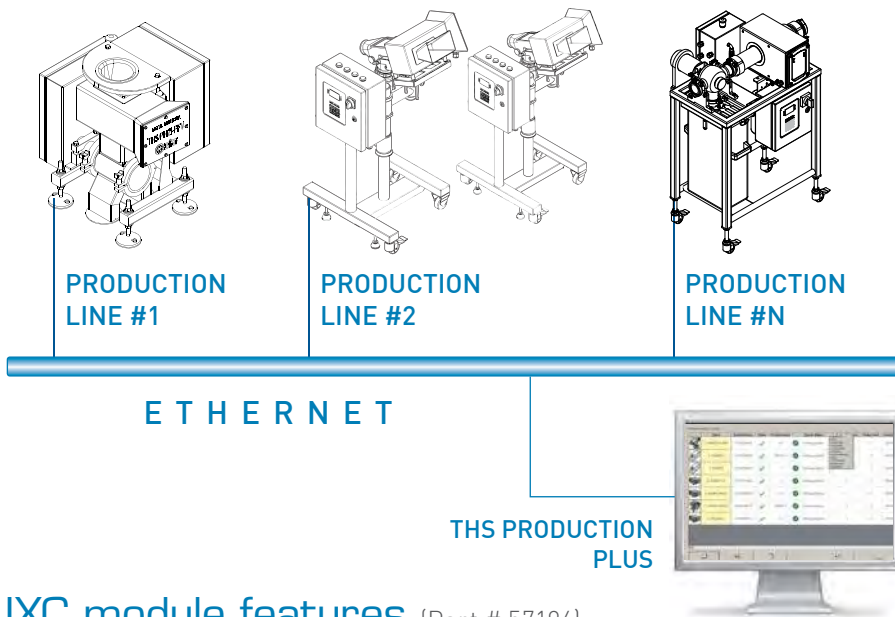

IXC module features (Part # 57194)

- Gateway to THS Production Net Management System
- Integrated Web-server
- Dual 100base-T Ethernet
- Dual Full Speed USB interface
- Wi-Fi 802.11b/g
- 100.000 events internal data logger

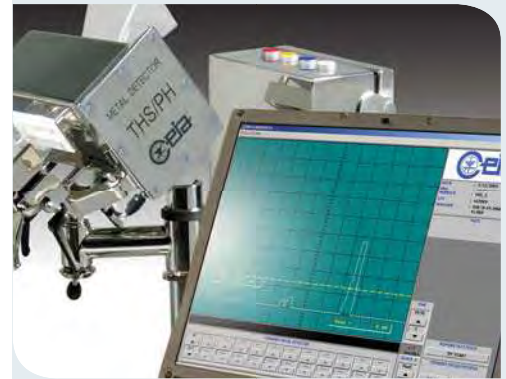

MD-SCOPE (PART # MD-SCOPE2)

SOFTWARE DIAGNOSTIC PACKAGE COMPLETE WITH CONNECTOR CABLE AND HARDWARE KEY:

- ▶ REMOTE PROGRAMMING
- ▶ SIGNAL INPUT/OUTPUT
- ▶ ALARM THRESHOLD AND AMPLITUDE OF THE SIGNAL

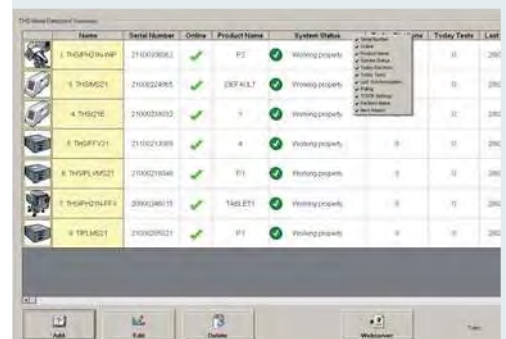

Name	Serial Number	Online	Product Name	System Status	Unit	Today Events	Last
1. THS/PH21A1	2100219061	✓	PS	Working properly	1	0	200
2. THS/PH21A1	210022885	✓	SK7 NLT	Working properly	1	0	200
3. THS/PH21A1	210023803	✓	9	Working properly	1	0	200
4. THS/PH21A1	210021908	✓	4	Working properly	1	0	200
5. THS/PH21A1	210021908	✓	BT	Working properly	1	0	200
6. THS/PH21A1	200024015	✓	1402 BT	Working properly	1	0	200
7. THS/PH21A1	210023952	✓	BT	Working properly	1	0	200

THS PRODUCTION PLUS

(PART # 33908)

- ▶ CONNECTS AND ACQUIRES DATA FROM MULTIPLE THS DETECTORS VIA ETHERNET LAN
- ▶ PROVIDES CONNECTION TO AN EXTERNAL DATABASE (OLE DB) AND DEFINITION OF A PROGRAMMABLE BLOCK OF SQL INSTRUCTIONS FOR EACH METAL DETECTOR EVENT
- ▶ ENABLES DATA BASE MANAGEMENT AND BACK-UP OF METAL DETECTOR EVENTS
- ▶ REPORT DATA EXPORTABLE IN HTML AND CSV FORMAT
- ▶ PROVIDES USER AUTHENTICATION AND MANAGES ELECTRONIC SIGNATURES AND RECORDS
- ▶ ALLOWS DATA INTEGRITY AND OPERATOR AUDITING
- ▶ FDA REQUIREMENTS COMPLIANT, TITLE 21 OF THE CODE OF FEDERAL REGULATIONS (CFR)

THS/PH21N



Ultra High Sensitivity Metal Detector

- AISI 316L stainless steel construction
- Control Power Box available according to UL 508A and CSA-C22.2 No. 14-05
- 500 product profiles, selectable by local programming or network software
- 10.000 storable events
- High-contrast graphic display
- Local programming: 16 stainless steel keys, 3 with double function
- Quick Access key for fast programming of user parameters



THS/PH21E



High Sensitivity Metal Detector

- AISI 316L stainless steel construction
- Control Power Box available according to UL 508A and CSA-C22.2 No. 14-05
- 250 product profiles, selectable by local programming or network software
- 1.000 storable events
- 4 x 20 character alphanumeric display
- Local programming: 4 stainless steel keys, 3 with double function

THS/PH21N-DT & THS/PH21E-DT

Dust Tight Pharmaceutical Metal Detection System

- Transit tunnel and ejection system completely sealed
- Easy integration with tablet press and deduster from the leading manufacturers
- Rapid maintenance does not require the employment of tools to assemble and disassemble the components



DUST TIGHT TRANSIT PIPE AND EJECTION SYSTEM PREVENTS DISPERSION OF THE PRODUCT

THS/PH21N-WIP & THS/PH21E-WIP

Wash-in-Place Pharmaceutical Metal Detection System

- Transit tunnel and ejection system completely sealed
- Fitted with nozzles for washing water injection and decontamination
- Easy integration with tablet press and deduster from the leading manufacturers



A SPECIAL BUILT-IN WASHING SYSTEM ALLOWS COMPLETE CLEANING OF THE CONDUITS AFTER COMPLETION OF EACH PRODUCTION BATCH

THS/PH21N-D25

Specific inspection against tiny metal particle contamination

- Unsurpassed Detection
- Best Product Quality
- Round aperture
- Applications:
 - ✓ R&D analysis
 - ✓ Rework confirmation
 - ✓ Root cause analysis assistance
 - ✓ New product specification



Mechanical Data

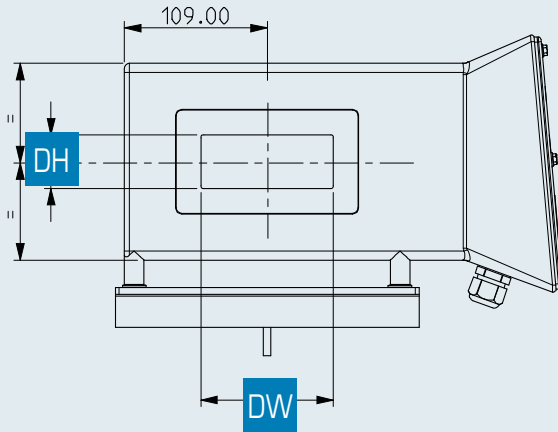
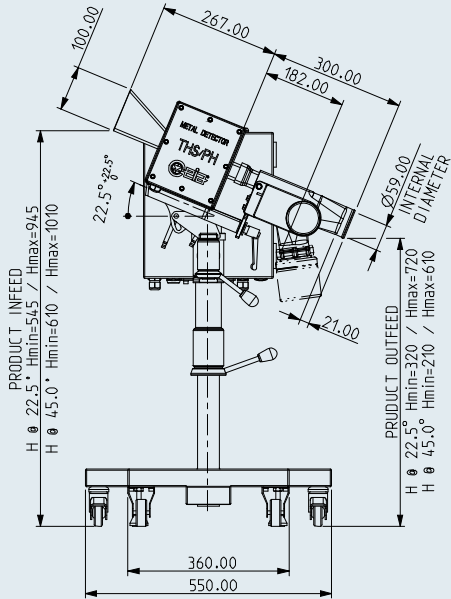

Dimensions (mm)

Aperture size
(DW x DH)

	Models		
	THS/PH21N THS/PH21E	THS/PH21N-DT THS/PH21E-DT	THS/PH21N-WIP THS/PH21E-WIP
	90 x 25 mm	90 x 25 mm	90 x 25 mm
	100 x 40 mm	100 x 40 mm	100 x 40 mm

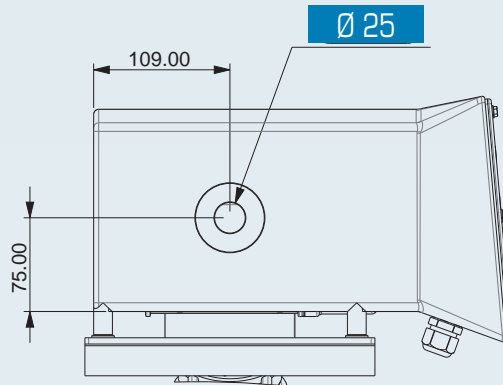
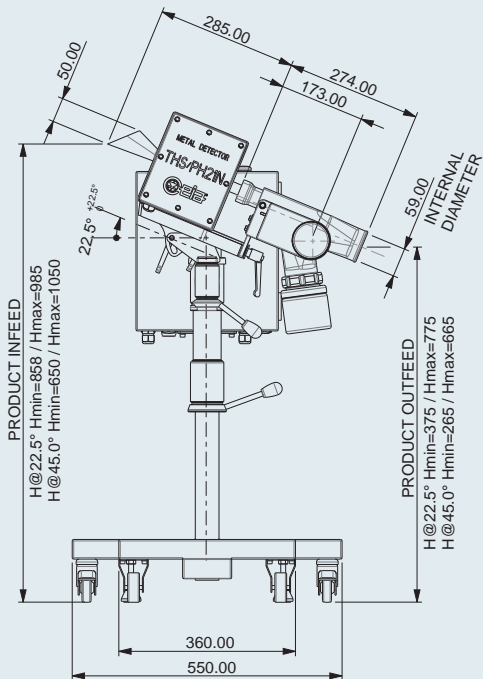

Dimensions (mm)

Model

THS/PH21N-D25

Aperture size

Ø 25



Integrated Systems for Granular, Liquid and Powder Products

THS/PH21N-FFV & THS/PH21E-FFV

Integrated System for Granular and Powder Products

- Ultra High Sensitivity to all metals
- Very compact size
- AISI 316L stainless steel construction
- Control Power Box available according to UL 508A and CSA-C22.2 No. 14-05
- ATEX ZONE 21 version (available on demand)



THE EJECTION SYSTEM IS FITTED WITH AN INNOVATIVE DEFLECTOR THAT FEATURES QUICK RESPONSE, PRECISE EJECTION OF THE CONTAMINATED PRODUCT AND HIGH PRODUCTION FLOW RATE

Dimensions (mm)

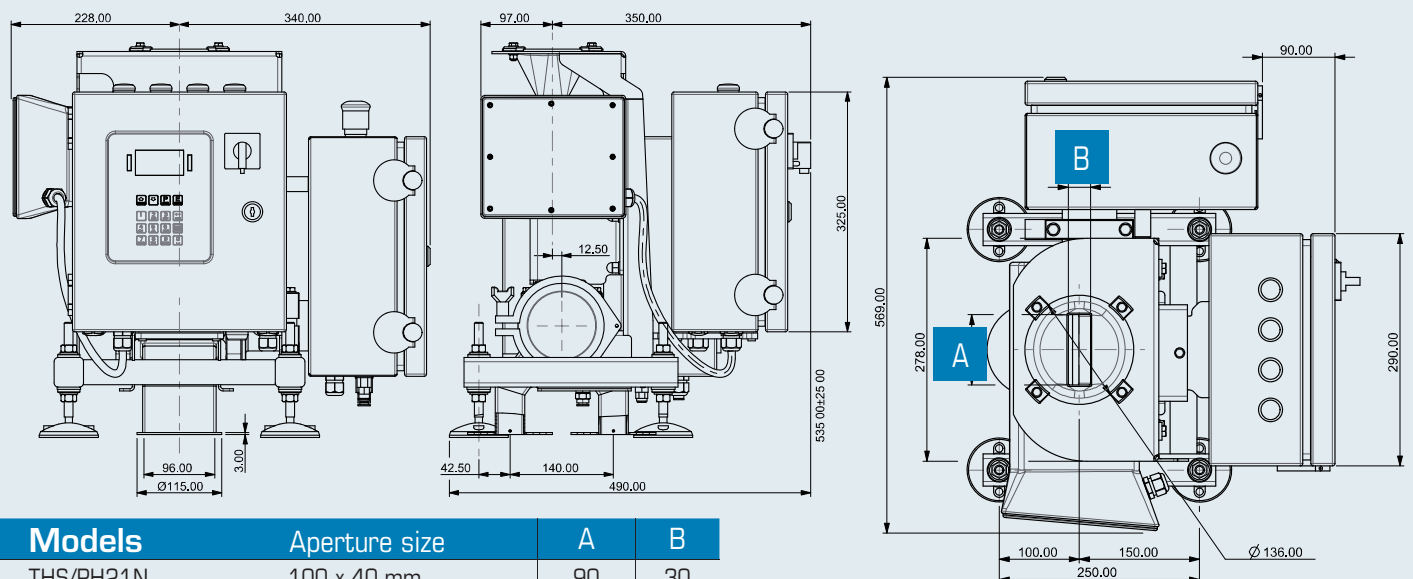

Models	Aperture size	A	B
THS/PH21N	100 x 40 mm	90	30
THS/PH21E	90 x 25 mm	78	13

THS/FFV 21 series

Large Aperture Integrated System for Granular and Powder Products

- Wide range of standard pipe sizes available to suit all applications
- Enhanced product throughput rate
- AISI 316L stainless steel construction
- Compact size
- Fast and efficient: achieve fast ejection speeds and accuracy, with the minimum amount of rejected product
- Pipe in antistatic material, certified for contact with food products



THS/FFV 21S

THS/FFV 21 models	aperture diameter
THS/FFV21S-75	Ø 75
THS/FFV21S-100	Ø 100
THS/FFV21R-150	Ø 150
THS/FFV21R-200	Ø 200

THS/PLV 21 series

Integrated System for Liquid and Viscous Products

- Wide range of standard pipe sizes available to suit all applications
- Full compliance with HACCP criteria
- AISI 316L stainless steel construction
- Fast acting reject device for a limited quantity of rejected product
- Easy to clean and inspect



THS/PLV 21

THS/PLV 21 models	clamp diameter
THS/PLV21-38	Ø 38
THS/PLV21-50	Ø 50
THS/PLV21-63	Ø 63
THS/PLV21-75	Ø 75

Conveyor Inspection Systems

- High Sensitivity to all metals
- Integrated controls for line speed and rejection
- High immunity to environmental interference
- Automatic learning & tracking of product effect
- Easy to maintain and inspect
- Digitally adjustable belt speed
- Control Power Box available according to UL 508A and CSA-C22.2 No. 14-05
- Applications: Flacons Bottles Packaging Loose product



Basic Configuration

optical signalling device		acoustic signalling device	
belt stop in case of alarm		synchronization photocell	
variable speed		complete reversibility of the accessory assembly and of the Metal Detector	
conveyor belt dimensions (LxWxH)			
		1800 mm x 85 mm x 875 mm	1800 mm x 150 mm x 875 mm
type of stand	feet	●	●
	castors	○	○
flap reject		○	○
ejection confirmation/bin full kit		○	○
insufficient air pressure control kit		○	○
side panels for product containment		●	●
test due signalling device (blue)		○	○
● STANDARD ○ ACCESSORIES / OPTIONALS			



THS/FBB, FLAT CONVEYOR BELT SYSTEM



THS/MBB, MODULAR CONVEYOR BELT SYSTEM