

## SPBC

### SPBC SERIES SINGLE POINT LOAD CELLS

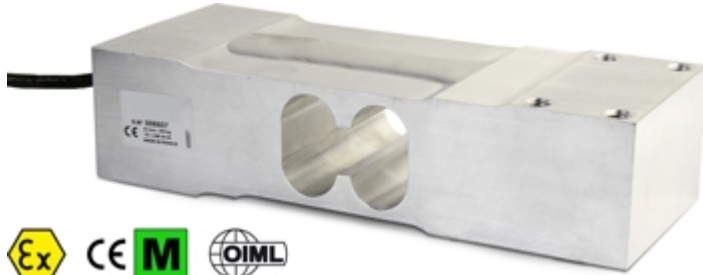

Load cells for off center loads, suitable for example to build CE-M approved scales with a single load cell with maximum dimensions of 700x700 mm.

---

**CAPACITIES (kg):** 100, 200, 300, 500, 630.

---

**OIML R60. C3** precision class.

---

**Aluminium** alloy. **IP65** protection.

---

Working in cooperation with:

**UAB DESKA**

PRAMONES 5 - LT-94102 - KLAIPEDA - LITHUANIA  
Tel. 00370-46-381089 Fax. 00370-445-76466  
info@deska.lt

The best solution  
for advanced industrial  
applications

## MAIN FEATURES

- C3 PRECISION CLASS
- OFF CENTER LOAD COMPENSATED
- MADE IN ALUMINIUM ALLOY
- IP65 PROTECTION
- MAX. CAPACITIES FROM 100 TO 630kg
- FOR PLATFORMS WITH DIMENSIONS UP TO 700 X 700 mm
- SHIELDED CONNECTION CABLE
- OIML CERTIFICATE AVAILABLE UPON REQUEST
- TEST CERTIFICATE AVAILABLE UPON REQUEST

## TECHNICAL FEATURES

- Minimum load cell verification interval:  $V_{min} = E_{Max} / 10.000$
- Maximum number of verification intervals:  $n_{LC} = 3000$
- Full Scale Output: 2mV/V +/- 10%
- Combined error: 0,017% of Full Scale Output (F.S.)
- Temperature effect on zero: 0,0028% /°C
- Temperature effect on full scale output: 0,0014% /°C
- Compensated Temperature Range: -10°C/+40°C
- Operating Temperature Range: -20°C/+60°C
- Creep error after 30 minutes: 0,025% F.S.
- Maximum tolerated excitation voltage: 15 VDC
- Input Resistance: 410 ± 10 Ohm
- Output Resistance: 350 ± 5 Ohm
- Zero Balance: +/-10% F.S.
- Insulation Resistance: >1000 MOhm
- Safe Overload: 150% F.S.
- Ultimate Overload: 200% F.S.
- Nominal displacement: < 1mm
- SPBC 6-wire shielded cable, 3m long, 5mm diameter

## ATEX Version

- The CCATEX certificate makes the load cell suitable for use in hazardous areas with protection methods according to:  
ATEX II 1G Ex ia IIC T6 (Ta -20÷+40°C) TX (Ta -20÷+65°C) Ga  
ATEX II 1D Ex ta IIIC TX°C (Ta -20÷+40°C) TX°C (Ta -20÷+65°C) Da IP65.  
The certificate includes the manual and the ATEX CE conformity declaration (available in EN, DE, FR, and IT).
- **IMPORTANT:** the certificate refers to the single load cell. For systems with more load cells, it is necessary to order one certificate for each load cell.

## DETAIL 1

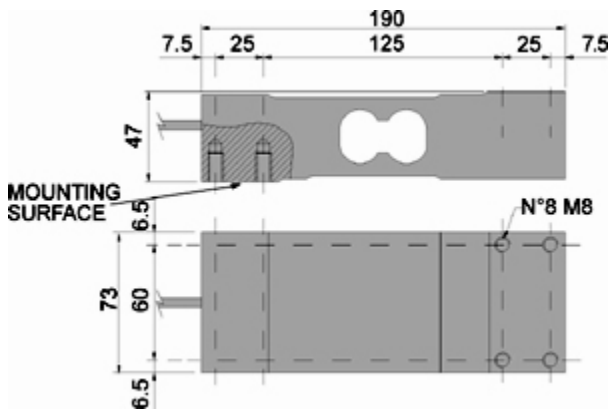



Dimensions (mm)

SPBC Wiring Code	
<i>Colour</i>	<i>Function</i>
--	SHIELD
YELLOW	OUTPUT +
GREY	SENSE +
BROWN	INPUT +
WHITE	OUTPUT -
GREEN	INPUT -
PINK	SENSE -

## VERSIONS

### Available versions

Codice	Piatto Max (mm)	Max (kg)
SPBC100 	700x700	100
SPBC200 	700x700	200
SPBC300 	700x700	300
SPBC500 	700x700	500
SPBC630 	700x700	630



www.diniargeo.com



“YOUR WORLDWIDE PARTNER FOR WEIGHING,”

DINI ARGEO  
FRANCE sarl  
Nogent-sur-Marne

DINI ARGEO  
GMBH  
Sinsheim - Germany

DINI ARGEO  
UK Ltd  
Taunton - United Kingdom

DINI ARGEO WEIGHING  
INSTRUMENTS Ltd  
Shanghai - China

DINI ARGEO  
WEIGHBRIDGES  
Calto (RO) – Italy



HEAD OFFICE  
Via Della Fisica, 20  
41042 Spezzano di Fiorano Modena - Italy



**UAB DESKA**

PRAMONES 5 - LT-94102 - KLAIPEDA - LITHUANIA

Tel. 00370-46-381089 Fax. 00370-445-76466

info@deska.lt

SALES AND TECHNICAL ASSISTANCE SERVICE